



FIBER DISTRIBUTION SUPPORT FOR ADSS CABLES.

AR-FDS-60

SUSPENSION

The suspension serves to guarantee the weight of the optical cable. Make the famous "bellies" in the posts.



To use the suspension, the following material is required:

01 x AR-FDS-60	Dielectric support for optical cable suspension from 8mm to 16mm
01 x BAP3	Adjustable post clamp (Not shown in the photo)
01 x SRB14	Reinforced support for BAP (hole 14mm)
01 X PAR35	M12x35 PCA screw with hex nut

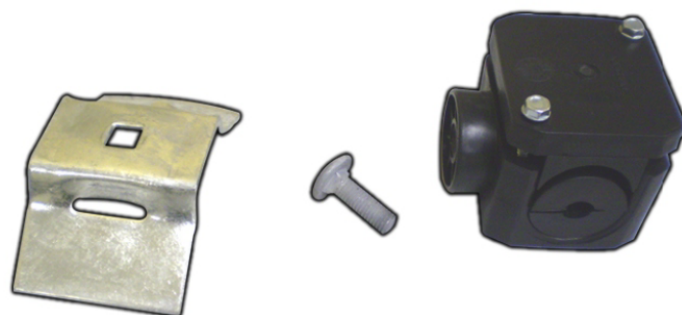

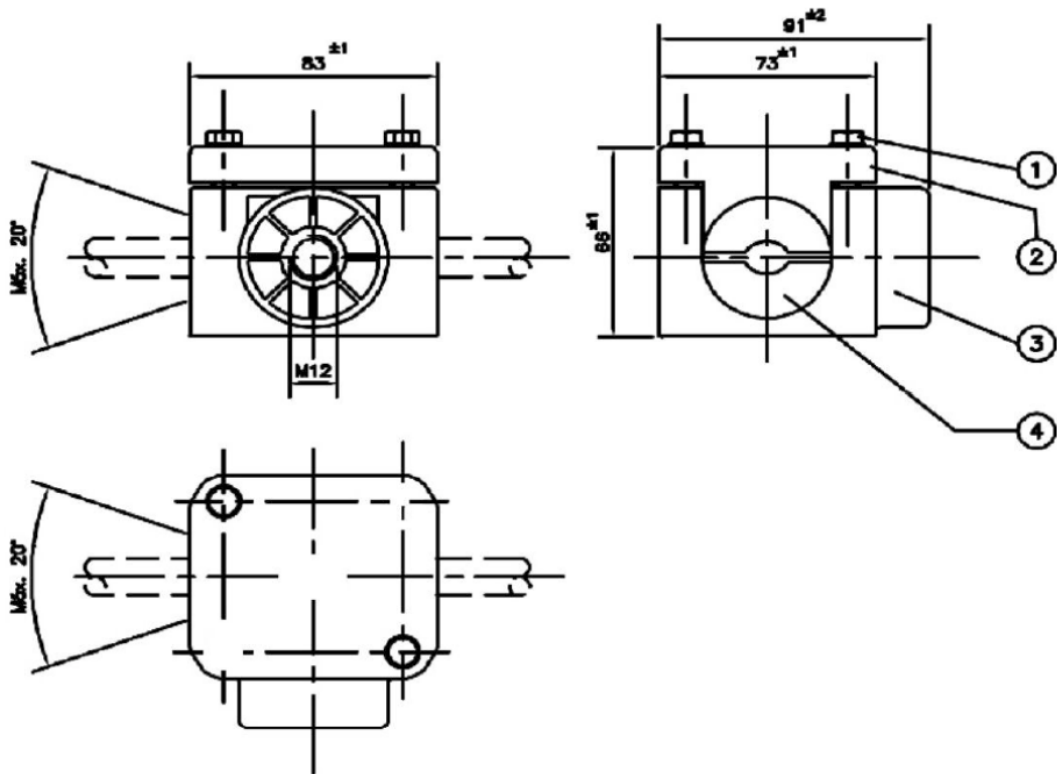
**NOTES:**

MATERIAL: VIEW TABLE

DIMENSIONS IN MILLIMETERS

APPROXIMATE WEIGHTS: 0.29KG

BREAKING LOAD, MINIMUM, VERTICAL: 300daN

BREAKING LOAD, MINIMUM, HORIZONTAL: 650daN

MINIMUM LOAD: 80 daN

REF	QUANT	DENOMINATION	MATERIAL	WEIGHT
1	2	HEX HEAD SCREW	STEEL 1010/1020 CADMIED	0.01
2	1	COVER	POLYPROPYLENE	0.073
3	1	BODY	POLYPROPYLENE	0.15
4	2	INSERT	PVC COMPOUND 85/80 SHORE A	0.04